



CDT2302

150KH2A Step-Down DC/DC Converter

● Features

- 3.3V, 5V, 12V and Adjustable Output
- Adjustable Version Output Voltage Range
1.23V to 18V \pm 4%
- Available in SOP-8 Packages
- Output Load Current 2A
- Input Voltage Range up 22V
- 150KHz \pm 15% Fixed Frequency
- Low Power Standby Mode
- Thermal Shutdown and Current Limited Protection
- TTL Shutdown Capability

● General Description

The CDT2302 series are monolithic integrated circuits that provide a step-down switching regulator, and capable of driving a 2A load with excellent line and load regulation.

These devices are available in fixed output voltage of 3.3V, 5V, 12V, and adjustable output version. Requiring a minimum number of external components, these regulators are simple to use and include internal frequency compensation and a fixed-frequency oscillator.

The CDT2302 operates at a switching frequency of 150 KHz thus allowing smaller sized filter components than what would be needed with lower frequency switching regulators. The device features include a guaranteed \pm 4% tolerance on output voltage under specified input voltage and output load conditions, and \pm 15% on the oscillator frequency. It does also provide external shutdown, current limited and over temperature shutdown functions for complete protection under fault conditions. The packages are available in a standard SOP-8 package.

● Applications

- On-card switching regulators
- Simple high efficiency step-down (buck)regulator
- Positive to negative converter

● Pin Assignment

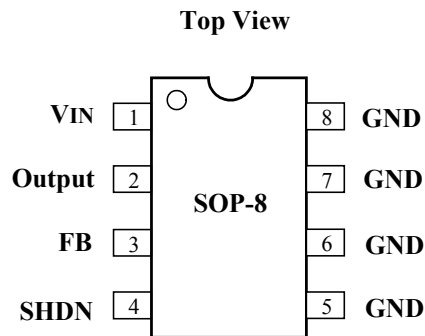

● Ordering Information

CDT2302-X XX

Package Type
S: SOP-8L

Output Voltage
33 : 3.3V
50 : 5.0V
12 : 12V
ADJ : Adjustable

● Pin Description

NO.	PIN_NAME	FUNCTION
1	VIN	Supply Voltage Pin
2	Output	Switch Pin. Connect inductor/diode here
3	FB	Feedback Pin.
4	SHDN	Shutdown Control Pin. Active-Low into shutdown mode
5-8	GND	Ground Pin

● Typical Application Circuit

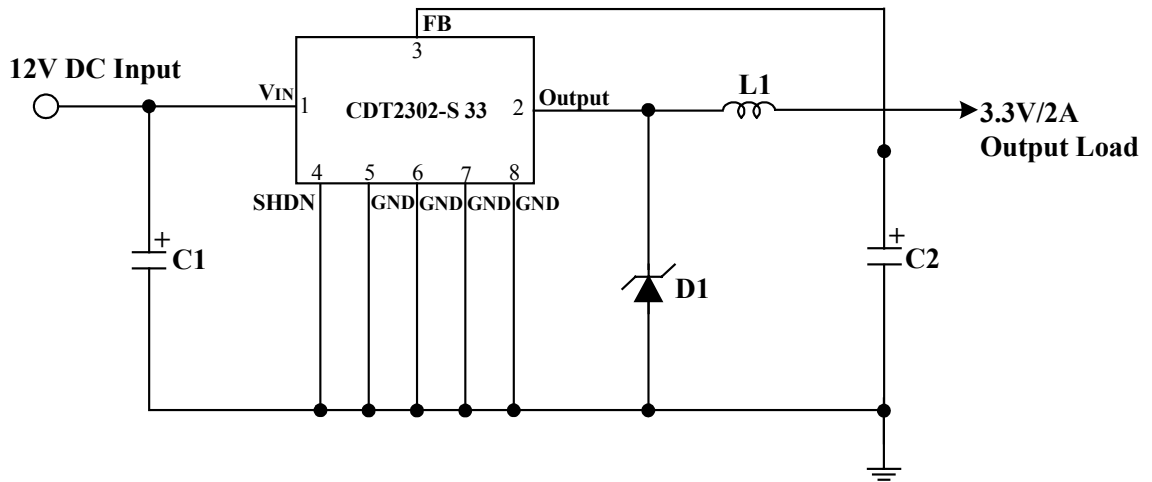

● Block Diagram

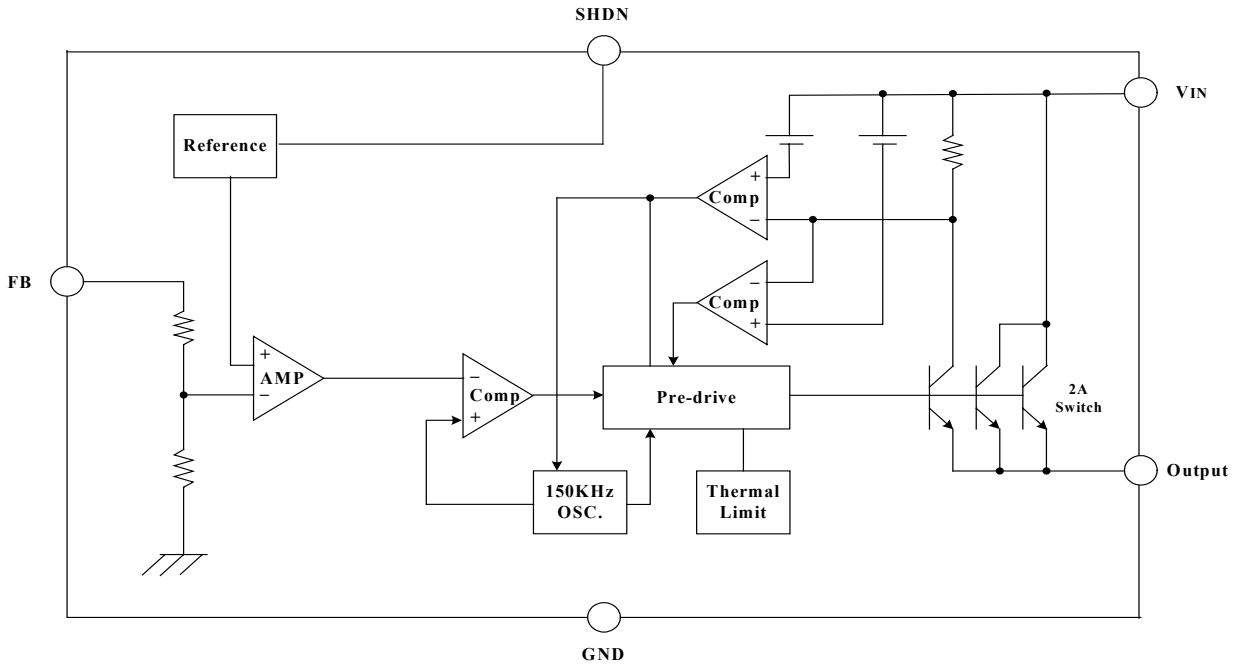

● Absolute Maximum Ratings

- Supply Voltage ----- -0.3V to 22V
- Input Voltage ----- -0.3V to $V_{DD}+0.3V$
- Operating Temperature ----- -40°C to 125°C
- Storage Temperature----- -50°C to 125°C

* Note : Stresses above those listed may cause permanent damage to the devices.

● Electrical Characteristic

(Specifications with standard type face are for $T_J=25^\circ\text{C}$, and those with **boldface type** apply over **full Operating Temperature Range**. Unless otherwise specified. $V_{IN}=12V$ for the 3.3V, 5V, Adjustable version and $V_{IN}=18V$ for the 12V Version $I_{LOAD}=500\text{mA}$)

Symbol	Parameter	Conditions	Min.	Typ.	Max.	Unit
I_{FB}	Feedback bias Current	$V_{FB} = 1.3V$ (Adjustable Only)		40	60	nA
					100	
F_{OSC}	Oscillator Frequency		127	150	173	KHz
			110		173	
V_{SAT}	Saturation Voltage	$I_{OUT} = 2A$, No outside circuit and $V_{FB} = 0V$ force driver on		1.5	1.6	V
					1.7	
DC	Max. Duty Cycle (ON)	$V_{FB} = 0V$ force driver on		100		%
	Min. Duty Cycle (OFF)	$V_{FB} = 12V$ force driver off		0		%
I_{CL}	Current Limit	Peak current, No outside circuit and $V_{FB} = 0V$ force driver on	3.6	4	5.5	A
					6.5	
I_{LEAK}	Output Leakage Current	Output = 0V, No outside circuit and $V_{FB} = 12V$ force driver off			200	μA
		Output = - 0.8V, $V_{IN} = 20V$		10	30	mA
I_Q	Quiescent Current	$V_{FB} = 12V$ force driver off		5	10	mA
I_{STBY}	Standby Quiescent Current	SHDN Pin = 5V, $V_{IN} = 20V$		150	250 300	μA
V_L	SHDN Pin Logic Input Threshold Voltage	Low (Regulator ON)		1.3	0.6	V
V_H		High (Regulator OFF)	2.0			
I_H	SHDN Pin Logic Input Current	$V_{LOGIC} = 2.5V$ (OFF)		15	25	μA
I_L		$V_{LOGIC} = 0.5V$ (ON)		0.02	5	
θ_{JC}	Thermal Resistance, θ_{JC}	SOP-8L	Junction to case		15	$^\circ\text{C}/W$
θ_{JA}	Thermal Resistance with Copper area of approximately 3 in ²	SOP-8L	Junction to ambient		70	$^\circ\text{C}/W$

• **CDT2302-ADJ**

Symbol	Parameter	Conditions	Typ.	Limit	Unit
VFB	Output Feedback	$5V \leq V_{IN} \leq 20V, 0.2A \leq I_{LOAD} \leq 2A,$ VOUT programmed for 3V	1.23	1.193/ 1.18 1.267/ 1.28	V V _{MIN} V _{MAX}
η	Efficiency	$V_{IN} = 12V, I_{LOAD} = 2A$	76		%

• **CDT2302-3.3V**

Symbol	Parameter	Conditions	Typ.	Limit	Unit
Vout	Output Feedback	$5.5V \leq V_{IN} \leq 20V, 0.2A \leq I_{LOAD} \leq 2A,$	3.3	3.168/ 3.135 13.432/ 3.465	V V _{MIN} V _{MAX}
η	Efficiency	$V_{IN} = 12V, I_{LOAD} = 2A$	78		%

• **CDT2302-5.0V**

Symbol	Parameter	Conditions	Typ.	Limit	Unit
Vout	Output Feedback	$8V \leq V_{IN} \leq 20V, 0.2A \leq I_{LOAD} \leq 2A,$	5	4.8/ 4.75 5.2/ 5.25	V V _{MIN} V _{MAX}
η	Efficiency	$V_{IN} = 12V, I_{LOAD} = 2A$	83		%

• **CDT2302-12V**

Symbol	Parameter	Conditions	Typ.	Limit	Unit
Vout	Output Feedback	$15V \leq V_{IN} \leq 20V, 0.2A \leq I_{LOAD} \leq 2A,$	12	11.52/ 11.4 12.48/ 12.6	V V _{MIN} V _{MAX}
η	Efficiency	$V_{IN} = 16V, I_{LOAD} = 2A$	90		%

(Specifications with standard type face for $T_J = 25^\circ C$, and those with boldface type apply over full operating temperature range)

● Operation Description

- **Pin Functions:**

VIN

This is the positive supply for the IC switching regulator. A suitable input bypass capacitor must be present at this pin to minimize voltage transients and to supply the switching currents needed by the regulator.

GND

Circuit ground

Output

Internal switch. The voltage at this pin switches between (+VIN – VSAT) and approximately – 0.5V, with a duty cycle of approximately VOUT/VIN. To minimize coupling to sensitive circuitry, the PC board copper area connected to this pin should be kept a minimum.

SHDN

Allows the switching regulator circuit to be shutdown using logic level signals thus dropping the total input supply current to approximately 150 μ A. Pulling this pin below a threshold voltage of approximately 1.3V turns the regulator on, and pulling this pin above 1.3V (up to a maximum of 18V) shuts the regulator down. If this shutdown feature is not needed, the SHDN pin can be wired to the ground pin or it can be left open, in either case the regulator will be in the ON condition.

FB

Senses the regulated output voltage to complete the feedback loop.

- **Thermal Considerations:**

The CDT2302 is available in a surface mount SOP-8. The size of the heatsink depends on the input voltage, the output voltage, the load current and the ambient temperature. The CDT2302 junction temperature rises above ambient temperature for a 2A load and different input and output voltage. The data was taken with the CDT2302 operating as a buck switching regulator in an ambient temperature of 25 °C (still air). These temperature rise numbers are all approximate and there are many factors that can affect these temperatures. Higher ambient temperature requires more heat sinking.

● Package Information

● 8-pin SOP outline dimensions

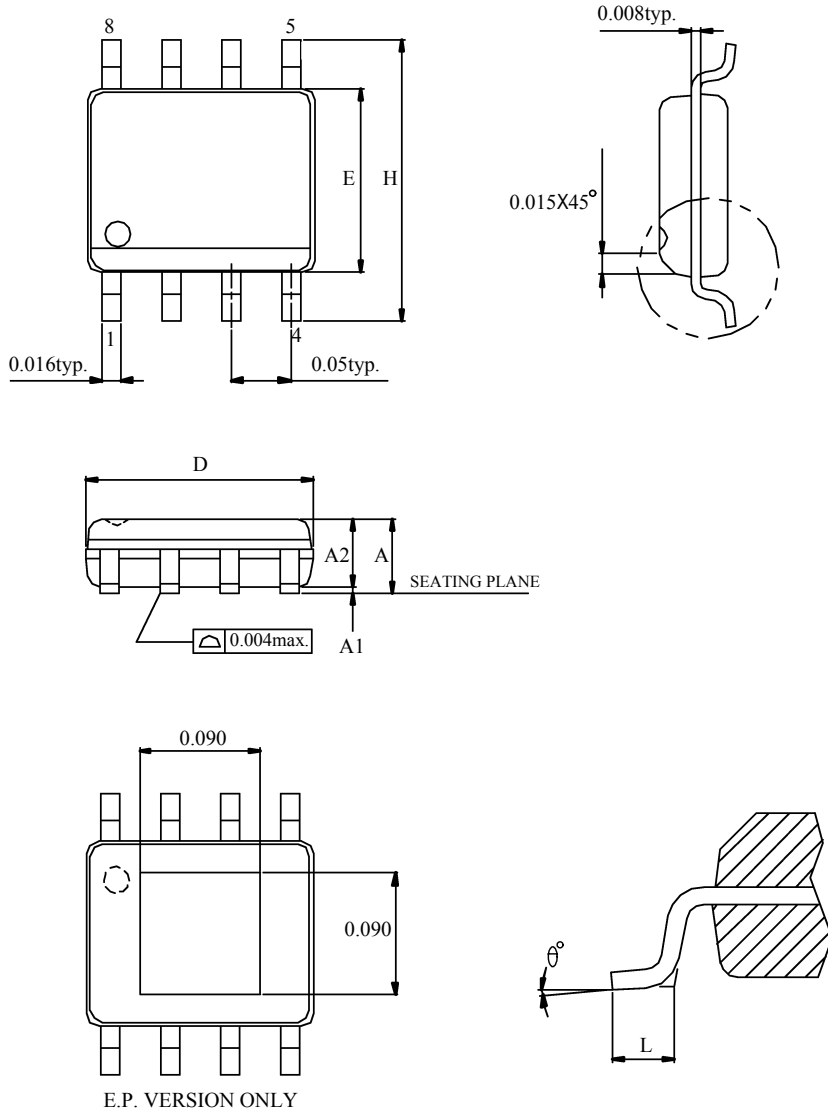

Symbols	MIN.	MAX.
A	0.053	0.069
A1	0.004	0.010
A2	—	0.059
D	0.189	0.196
E	0.150	0.157
H	0.228	0.244
L	0.016	0.050
θ	0	8

UNIT : INCH

NOTES.

1. JEDEC OUTLINE : MS-012 AA / E.P. VERSION : N/A
2. DIMENSIONS "D" DOES NOT INCLUDE MOLD FLASH, PROTRUSIONS OR GATE BURRS. MOLD FLASH, PROTRUSIONS AND GATE BURRS SHALL NOT EXCEED 0.15mm (0.006in) PER SIDE.
3. DIMENSIONS "E" DOES NOT INCLUDE INTER-LEAD FLASH, OR PROTRUSIONS. INTER-LEAD FLASH AND PROTRUSIONS SHALL NOT EXCEED 0.25mm (0.010in) PER SIDE.

* CDT assumes no responsibility for the use of the specification described. CDT reserves the right to modify the product specification without notice.
 (以上規格僅供參考，本公司得逕行修正，不另通知)