



CDT71XX

Low Quiescent Current 30mA Regulator

● General Description

The CDT71XX series is a three-terminal positive voltage regulator that is made by CMOS process. The CDT71XX series has higher precision output voltage and consumes less current than existing three-terminal voltage regulator. Battery power equipment can have a higher performance and a longer service life.

● Features

- Low Quiescent Current
- Low Drop Voltage
- Low Temperature Coefficient
- 24V Wide Supply Voltage Range
- Guaranteed 30mA Output Current
- $\pm 3\%$ Accuracy Output Voltage
- TO-92 and SOT-89 package

● Applications

- Battery power equipment
- Communication equipment
- Audio and video equipment
- Portable Device

● Selection Table

CDT71XX	
└───┬───	Output Voltage
30:	3.0V
33:	3.3V
36:	3.6V
44:	4.4V
50:	5.0V

● Pin Assignment

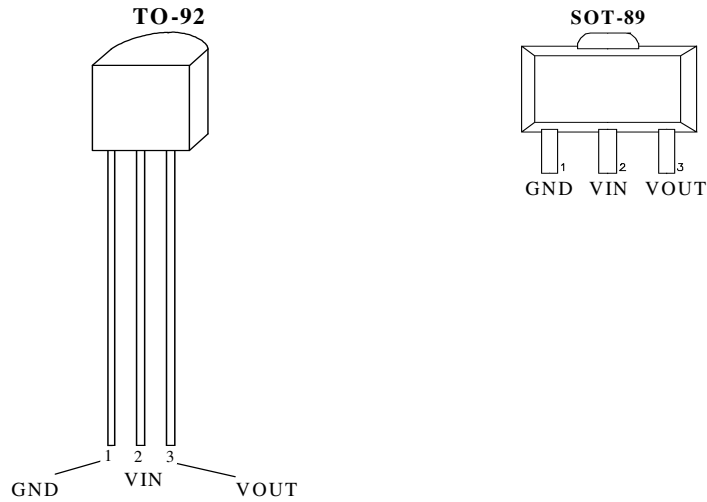

● Pin Description

NO.	PIN_NAME	I/O	FUNCTION
1	GND	P	Power (-)
2	VIN	P	Power (+)
3	VOUT	O	Output

● Block Diagram

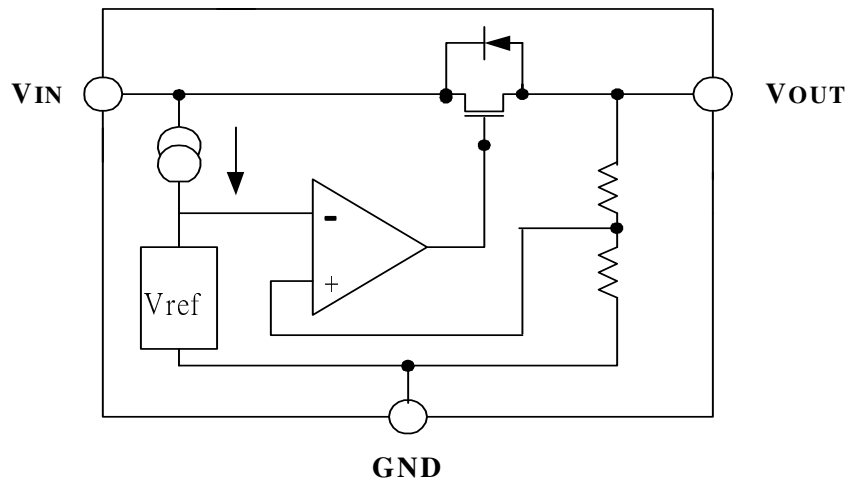

● Absolute Maximum Ratings

- Supply Voltage ----- -0.3V to 24V
- Input Voltage ----- -0.3V to $V_{IN}+0.3V$
- Operating Temperature ----- 0°C to 70°C
- Storage Temperature----- -50°C to 125°C

* Note : Stresses above those listed may cause permanent damage to the devices.

1. CDT7130

($V_{IN}=5V$, $T_a = 25^\circ C$, unless otherwise specified)

Symbol	Parameter	Conditions	Min.	Typ.	Max.	Unit
V_{IN}	Supply Voltage	—	—	—	24	V
V_{OUT}	Output Voltage	$V_{IN} = 5V, I_{OUT} = 10mA$	2.91	3.0	3.09	V
I_{OUT}	Output Current	$V_{IN} = 5V$	—	30	—	mA
ΔV_{OUT1}	Load Regulation	$V_{IN} = 5V, 1mA \leq I_{OUT} \leq 30mA$	—	60	100	mV
ΔV_{OUT2}	Line Regulation	$4V \leq V_{IN} \leq 24V, I_{OUT} = 1mA$	—	0.2	—	%/V
V_{DROP}	Drop Voltage	$I_{OUT} = 1mA$	—	90	—	mV
I_Q	Quiescent Current	$V_{IN} = 5V, \text{No Load}$	—	2.5	5.5	μA
$\frac{\Delta V_{OUT}}{\Delta T_a}$	Temperature Characteristic	$I_{OUT} = 10mA, 0^\circ C \leq T_a \leq 70^\circ C$	—	± 0.45	—	mV/°C

2. CDT7133

($V_{IN}=5V$, $T_a = 25^\circ C$, unless otherwise specified)

Symbol	Parameter	Conditions	Min.	Typ.	Max.	Unit
V_{IN}	Supply Voltage	—	—	—	24	V
V_{OUT}	Output Voltage	$V_{IN} = 5V, I_{OUT} = 10mA$	3.20	3.3	3.39	V
I_{OUT}	Output Current	$V_{IN} = 5V$	—	30	—	mA
ΔV_{OUT1}	Load Regulation	$V_{IN} = 5V, 1mA \leq I_{OUT} \leq 30mA$	—	60	100	mV
ΔV_{OUT2}	Line Regulation	$4V \leq V_{IN} \leq 24V, I_{OUT} = 1mA$	—	0.2	—	%/V
V_{DROP}	Drop Voltage	$I_{OUT} = 1mA$	—	90	—	mV
I_Q	Quiescent Current	$V_{IN} = 5V, \text{No Load}$	—	2.5	5.5	μA
$\frac{\Delta V_{OUT}}{\Delta T_a}$	Temperature Characteristic	$I_{OUT} = 0mA, 0^\circ C \leq T_a \leq 70^\circ C$	—	± 0.5	—	mV/°C

3. CDT7136

(V_{IN}=5V, T_a = 25°C, unless otherwise specified)

Symbol	Parameter	Conditions	Min.	Typ.	Max.	Unit
V _{IN}	Supply Voltage	—	—	—	24	V
V _{OUT}	Output Voltage	V _{IN} = 5V, I _{OUT} = 10mA	3.49	3.6	3.70	V
I _{OUT}	Output Current	V _{IN} = 5V	—	30	—	mA
ΔV _{OUT1}	Load Regulation	V _{IN} = 5V, 1mA ≤ I _{OUT} ≤ 30mA	—	60	100	mV
ΔV _{OUT2}	Line Regulation	4V ≤ V _{IN} ≤ 24V, I _{OUT} = 1mA	—	0.2	—	%/V
V _{DROP}	Drop Voltage	I _{OUT} = 1mA	—	90	—	mV
I _Q	Quiescent Current	V _{IN} = 5V, No Load	—	2.5	5.5	μA
$\frac{\Delta V_{OUT}}{\Delta T_a}$	Temperature Characteristic	I _{OUT} = 10mA, 0°C ≤ T _a ≤ 70°C	—	± 0.6	—	mV/°C

4. CDT7144

(V_{IN}=6.4V, T_a = 25°C, unless otherwise specified)

Symbol	Parameter	Conditions	Min.	Typ.	Max.	Unit
V _{IN}	Supply Voltage	—	—	—	24	V
V _{OUT}	Output Voltage	V _{IN} = 6.4V, I _{OUT} = 10mA	4.286	4.4	4.532	V
I _{OUT}	Output Current	V _{IN} = 6.4V	—	30	—	mA
ΔV _{OUT1}	Load Regulation	V _{IN} = 6.4V, 1mA ≤ I _{OUT} ≤ 30mA	—	60	100	mV
ΔV _{OUT2}	Line Regulation	5.4V ≤ V _{IN} ≤ 24V, I _{OUT} = 1mA	—	0.2	—	%/V
V _{DROP}	Drop Voltage	I _{OUT} = 1mA	—	90	—	mV
I _Q	Quiescent Current	V _{IN} = 6.4V, No Load	—	2.5	5.5	μA
$\frac{\Delta V_{OUT}}{\Delta T_a}$	Temperature Characteristic	I _{OUT} = 10mA, 0°C ≤ T _a ≤ 70°C	—	± 0.7	—	mV/°C

5. CDT7150

(V_{IN}=7V, T_a = 25°C, unless otherwise specified)

Symbol	Parameter	Conditions	Min.	Typ.	Max.	Unit
V _{IN}	Supply Voltage	—	—	—	24	V
V _{OUT}	Output Voltage	V _{IN} = 7V, I _{OUT} = 10mA	4.85	5.0	5.15	V
I _{OUT}	Output Current	V _{IN} = 7V	—	30	—	mA
ΔV _{OUT1}	Load Regulation	V _{IN} = 7V, 1mA ≤ I _{OUT} ≤ 30mA	—	60	100	mV
ΔV _{OUT2}	Line Regulation	6V ≤ V _{IN} ≤ 24V, I _{OUT} = 1mA	—	0.2	—	%/V
V _{DROP}	Drop Voltage	I _{OUT} = 1mA	—	90	—	mV
I _Q	Quiescent Current	V _{IN} = 7V, No Load	—	2.5	5.5	μA
$\frac{\Delta V_{OUT}}{\Delta T_a}$	Temperature Characteristic	I _{OUT} = 10mA, 0°C ≤ T _a ≤ 70°C	—	± 0.75	—	mV/°C

● Application Circuit

To avoid the surge voltages of V_{IN} , keep $C1$ with the capacitance of $10\mu F$. To reduce output ripple and improve response time of load, keep $C2$ with the capacitance of $10\mu F$. It's possible without each capacitance if V_{IN} side is closed to GND and output ripple is limited.

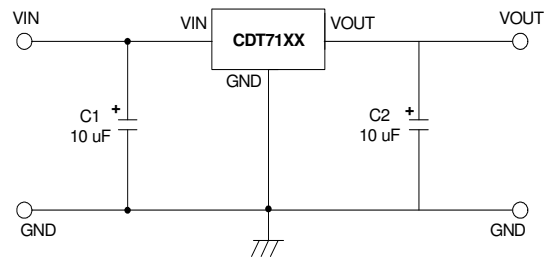

● Package Information

- TO-92 outline dimensions

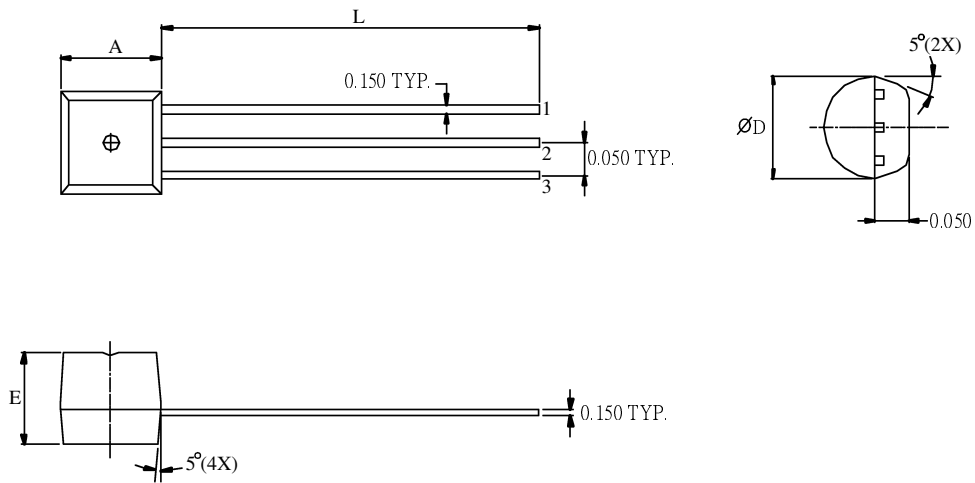

Symbols	INCHES		
	MIN.	NOR.	MAX.
A	0.170	0.180	0.210
$\varnothing D$	0.175	0.180	0.205
E	0.125	0.142	0.165
L	0.500	0.580	—

• SOT-89 outline dimensions

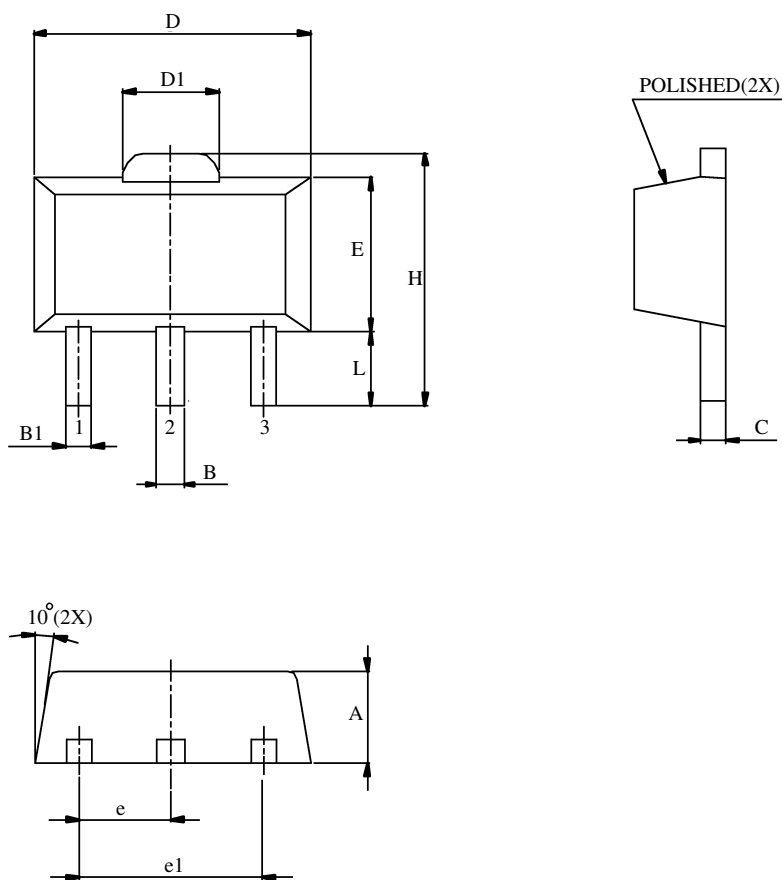

Symbols	MIN.	MAX.
A	1.40	1.60
B	0.44	0.56
B1	0.36	0.48
C	0.35	0.44
D	4.40	4.60
D1	1.35	1.83
E	2.29	2.60
H	3.94	4.25
e	1.50 BSC	
e1	3.00 BSC	
L	0.89	1.2

UNIT : MM

NOTES.

1. JEDEC OUTLINE : TO-243 AA
2. DIMENSION B1, 2 PLACES.

* CDT assumes no responsibility for the use of the specification described. CDT reserves the right to modify the product specification without notice.
 (以上規格僅供參考，本公司得逕行修正，不另通知)