



## CDT7550

## 十組燈泡輸出控制 IC

### ● 產品說明(General Description)

CDT7550 主要應用於汽車第三煞車燈，  
外接零件少，變化多端，應用廣泛。  
R C 振盪方式，速度容易調整，10 組輸出  
可以有多种接法，直接用於 12VDC 線路，  
更方便穩定。

### ● 產品特性(Features)

- CMOS 製程、低功率損耗
- 工作電壓：3.0~15V
- 利用 VR 來調整速度
- 燈組可以接成：
  - (1) 順閃
  - (2) 全亮不閃
  - (3) 同時閃
  - (4) 來回閃
  - (5) 連亮(L1, L1 L2, ....OFF ,L1...)
- 燈串可任接 2~10 組輸出
- 輸出端為正輸出，直接推動電晶體  
(NPN)或接 LED 組

### ● 產品應用(Applications)

- 汽車煞車燈
- 警示燈

### ● 位置圖(Pad Assignment)

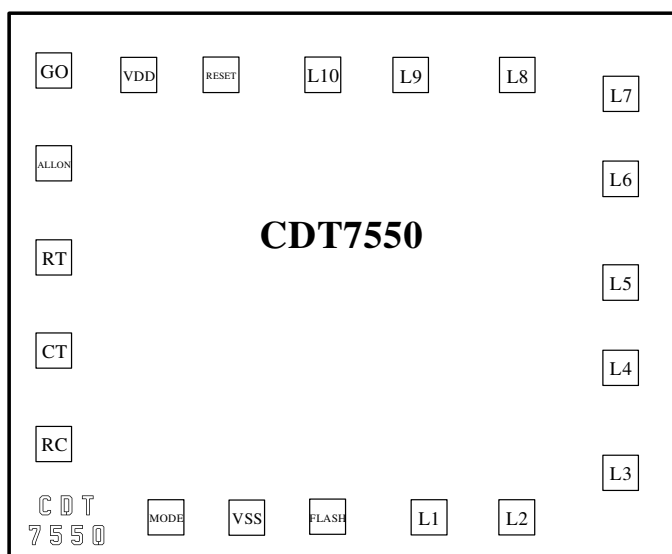

### ● Pad 座標(Pad Coordinates)

(Unit:um)

No.	Symbol	X	Y	No.	Symbol	X	Y
1	VDD	345	1320	11	L2	1335	120
2	GO	120	1330	12	L3	1610	245
3	ALLON	120	1080	13	L4	1610	525
4	RT	120	825	14	L5	1610	755
5	CT	120	575	15	L6	1610	1035
6	RC	120	320	16	L7	1610	1270
7	MODE	415	120	17	L8	1340	1320
8	VSS	625	120	18	L9	1060	1320
9	FLASH	840	120	19	L10	825	1320
10	L1	1105	120	20	RESET	560	1320

Chip Size = 1850 \* 1570 um

Note : IC 底座接 VDD

● 腳位圖 (Pin Assignment)

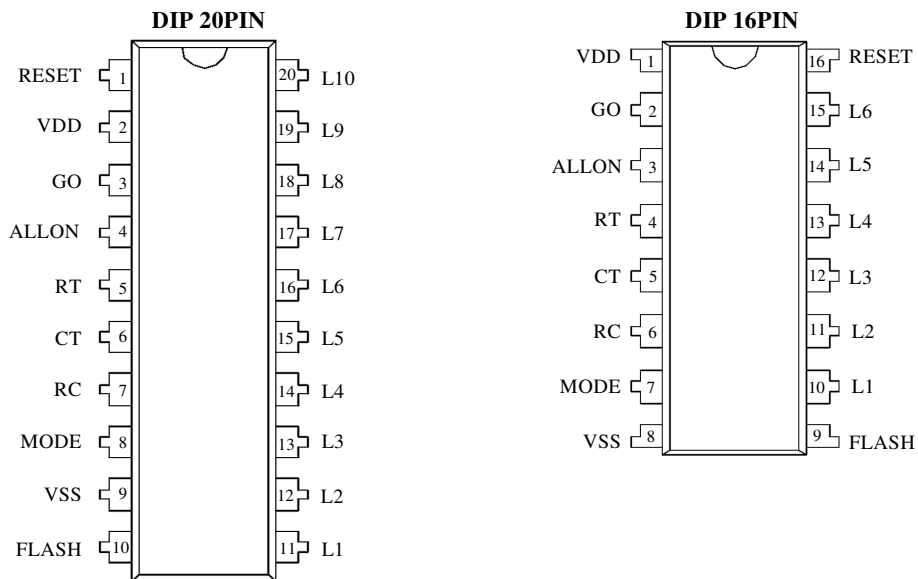

● 腳位說明 (Pad Description and Pin Description)

NO.		NAME	I/O	FUNCTION
20Pi	16Pin			
1	16	RESET	I	調整輸出個數
2	1	VDD	P	電源正端
3	2	GO	I	來回閃控制輸入
4	3	ALLON	I	全亮控制輸入
5	4	RT	O	振盪器輸出+電阻
6	5	CT	O	振盪器輸出+電容
7	6	RC	I	振盪器輸入
8	7	MODE	I	連亮控制輸入
9	8	VSS	P	電源負端
10	9	FLASH	I	同時閃控制輸入
11	10	L1	O	LED 輸出端
12	11	L2	O	
13	12	L3	O	
14	13	L4	O	
15	14	L5	O	
16	15	L6	O	
17		L7	O	
18		L8	O	
19		L9	O	
20		L10	O	

● 功能方塊圖(Block Diagram)

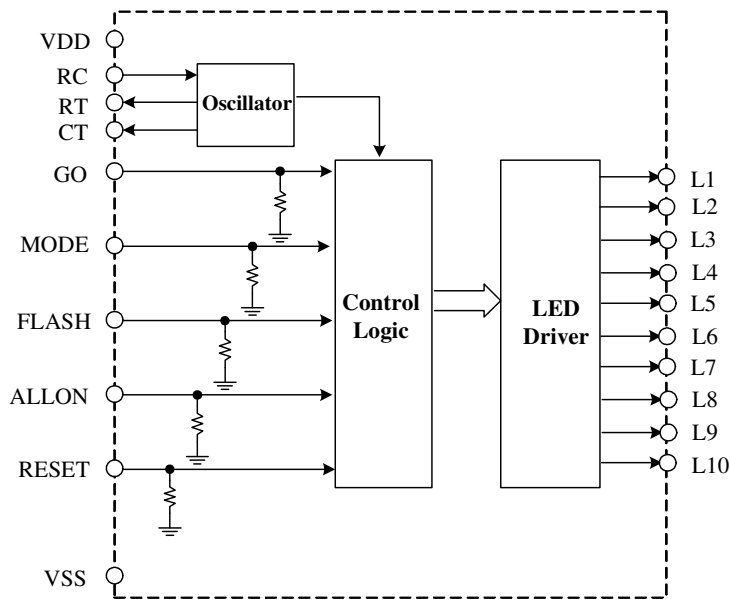

● 最大額定範圍(Absolute Maximum Ratings)

- Supply Voltage ----- -0.3V to 15V
- Input Voltage -----  $V_{SS}-0.3$  to  $V_{DD}+0.3$
- Operating Temperature ----- 0°C to 70°C
- Storage Temperature----- -50°C to 125°C

\* Note : Stresses above those listed may cause permanent damage to the devices.

● 電氣特性(Electrical Characteristics)

(  $V_{DD}=12V$ ,  $T_A = 25^\circ C$ , unless otherwise specified)

Symbol	Parameter	Condition	Min.	Typ.	Max.	Units	
$V_{DD}$	Supply Voltage		3.0	12	15	V	
$V_{IH}$	Input High Voltage		$0.7V_{DD}$		$V_{DD}+0.3$	V	
$V_{IL}$	Input Low Voltage		-0.3		$0.3V_{DD}$	V	
$I_{DD}$	Operating Current	@ $V_{DD} = 12V$ , no load		300		$\mu A$	
FOSC	Frequency	Rosc = 1M $\Omega$ , C=104		9		Hz	
$I_{OH}$	Source Current (L1~L10)	@ $V_{DD} = 12V$ , $V_{OH}=10V$		7		mA	
$I_{OL}$	Sink Current (L1~L10)	@ $V_{DD} = 12V$ , $V_{OL}=2V$		9		mA	
$R_{IN}$	Pull-low resistor of input pin	@ $V_{DD} = 12V$	MODE		6		K $\Omega$
		GO, ALLON, FLASH, RESET			8		K $\Omega$

## ● 功能說明(Function Description)

- (1). 當 GO, ALLON, MODE, FLASH 皆空接時，輸出為順閃。
- (2). 當 GO 接 VDD 時，輸出為來回閃。  
 當 ALLON 接 VDD 時，輸出為全亮。  
 當 MODE 接 VDD 時，輸出為連閃。  
 當 FLASH 接 VDD 時，輸出為全閃。

## ● 應用線路圖(Application Circuit)

- (1). 接燈泡(20Pin DIP)

(12VDC、平常時—順閃、煞車時—全亮、全閃、來回閃、連亮任選)

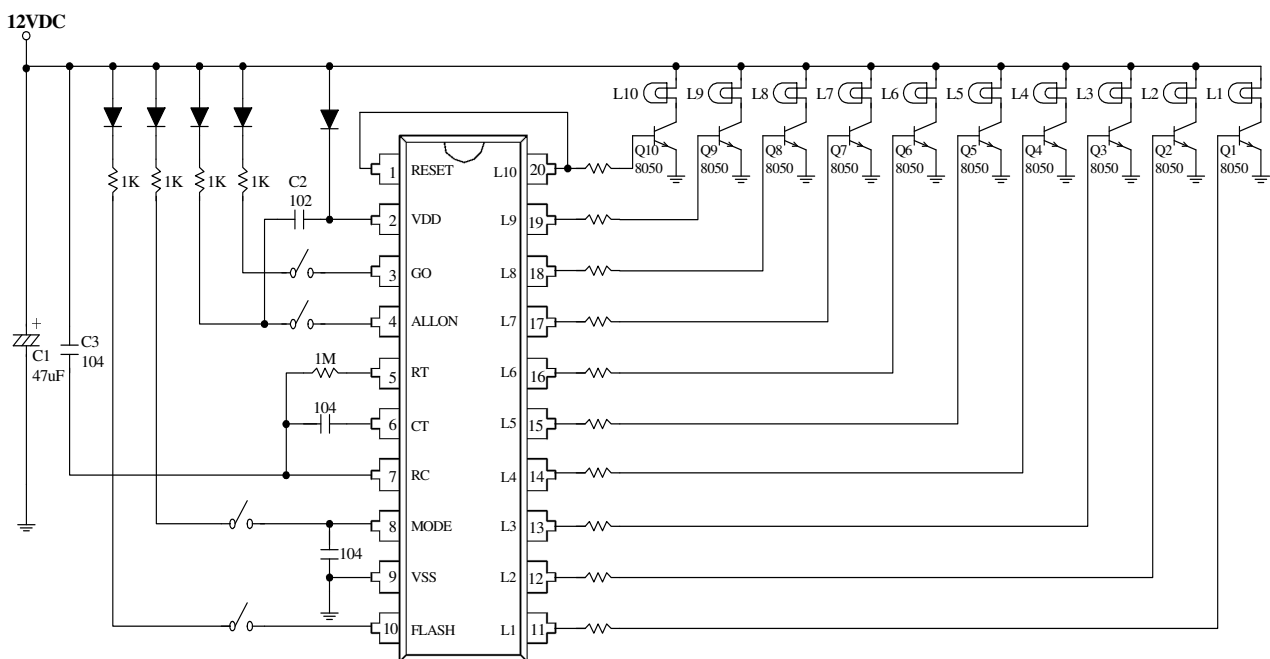

## (2). 接 LED (20Pin DIP)

(12VDC、平常時—順閃、煞車時—全亮、全閃、來回閃、連亮任選)

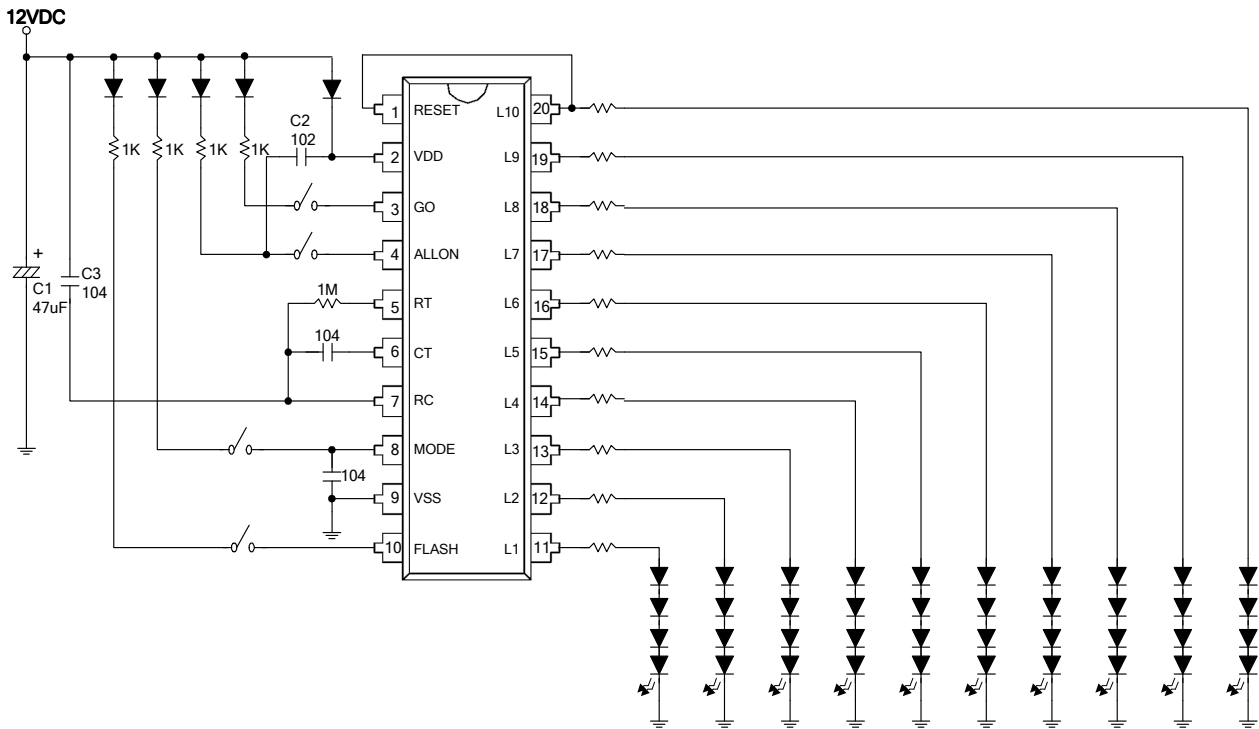

## (3). 接燈泡 (16Pin DIP)

(12VDC、平常時—順閃、煞車時—全亮、全閃、來回閃、連亮任選)

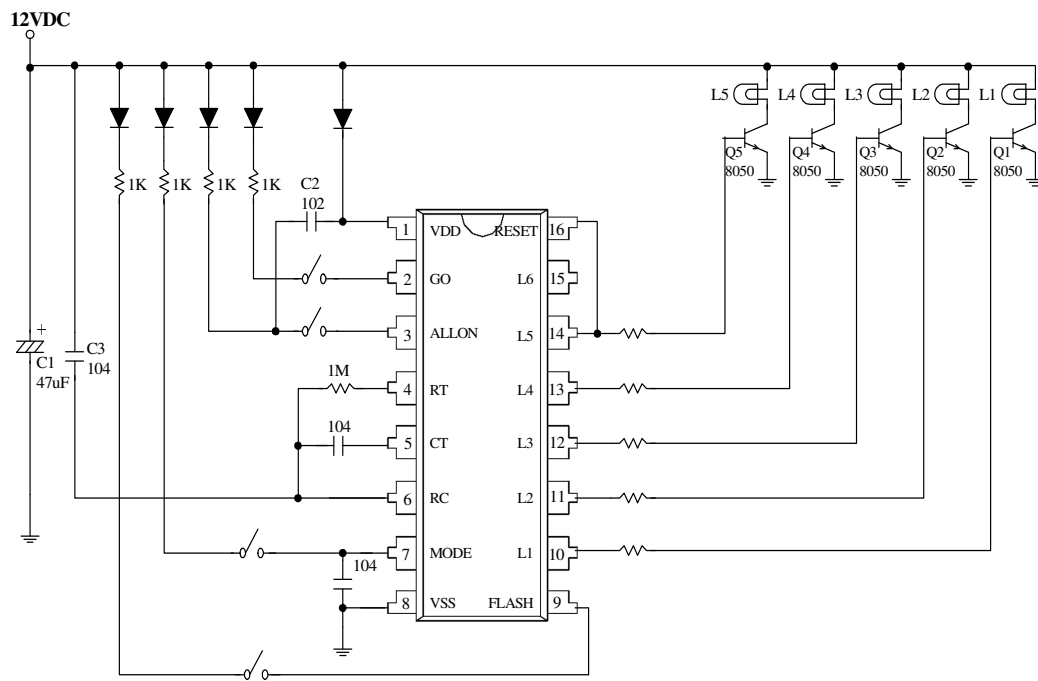

#### (4). 接 LED (16Pin DIP)

(12VDC、平常時—順閃、煞車時—全亮、全閃、來回閃、連亮任選)

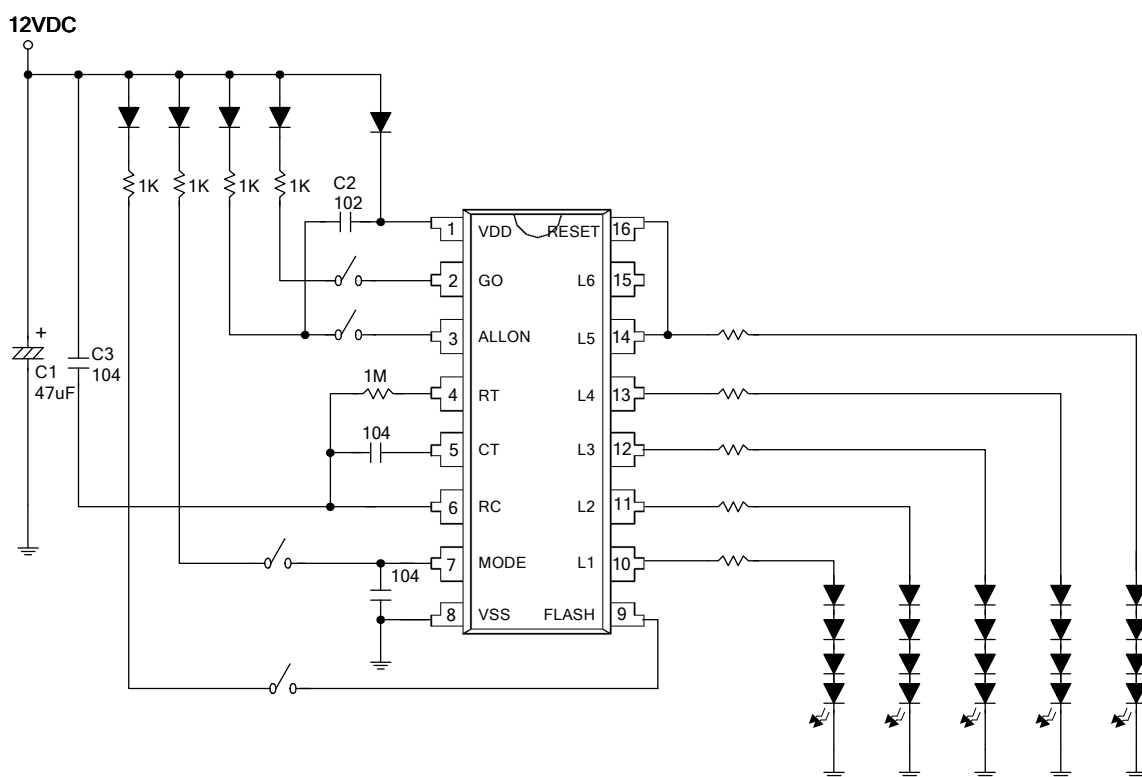

#### • 使用說明

1. 為了彌補 IC 在燈泡大電流 Power On Reset 之問題，請線路務必加 C1=47µF 以及在 ALLON 處加 C2=102，以彌補 IC 啟動之穩定性。
2. 使用連亮時，L10 或最後一個須與 RESET PIN 接一起。
3. VDD 或任何輸入端接 IN4001—保護線路。  
由於汽車內各控制端輸入電壓會不同，建議各控制輸入端在 IN4001 後再接一 1K 電阻，不要讓各控制輸入端之輸入電壓大於 VDD，否則 IC 容易燒壞。
4. MODE 使用時接一 104 到 VSS，不用時與 VSS 接一起。
5. 由於 IC 工作於高壓，POWER ON RESET 較不穩定。  
建議: RC pin 接一電容 104 到 VDD 以更加穩定 IC。
6. 因應用線路不同，使得輸出電流會不同，使用 RESET 功能時，與 RESET PIN 連接的 LED 輸出端上的電阻值要比其他 LED 輸出端上的電阻值較大，請自行調校增加幾百歐姆值，RESET 功能才能正常使用。

## ● Package Information

### • 20-pin DIP outline dimensions

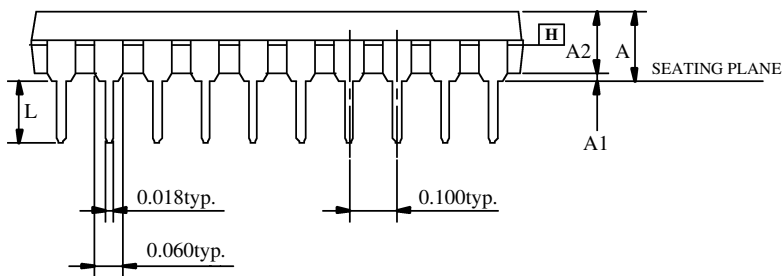
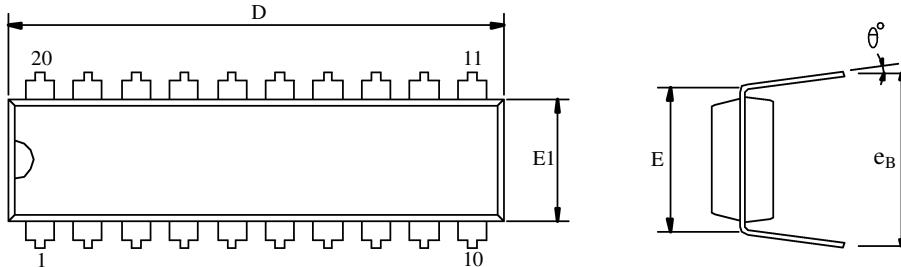

Symbols	MIN.	NOR.	MAX.
A	—	—	0.210
A1	0.015	—	—
A2	0.125	0.130	0.135
D	0.980	1.030	1.060
E	0.300 BSC.		
E1	0.245	0.250	0.255
L	0.115	0.130	0.150
e <sub>B</sub>	0.335	0.355	0.375
θ <sup>0</sup>	0	7	15

UNIT : INCH

#### NOTES.

1. JEDEC OUTLINE : MS-001 AD
2. "D", "E1" DIMENSIONS DO NOT INCLUDE MOLD FLASH OR PROTRUSIONS. MOLD FLASH OR PROTRUSIONS SHALL NOT EXCEED 0.010 INCH.
3. e<sub>B</sub> IS MEASURED AT THE LEAD TIPS WITH THE LEADS UNCONSTRAINED.
4. POINTED OR ROUNDED LEAD TIPS ARE PREFERRED TO EASE INSERTION.
5. DISTANCE BETWEEN LEADS INCLUDING DAM BAR PROTRUSIONS TO BE 0.005 INCH MINIMUM.
6. DATUM PLANE  $\square$  COINCIDENT WITH THE BOTTOM OF LEAD, WHERE LEAD EXIT BODY.

• 16-pin DIP outline dimensions

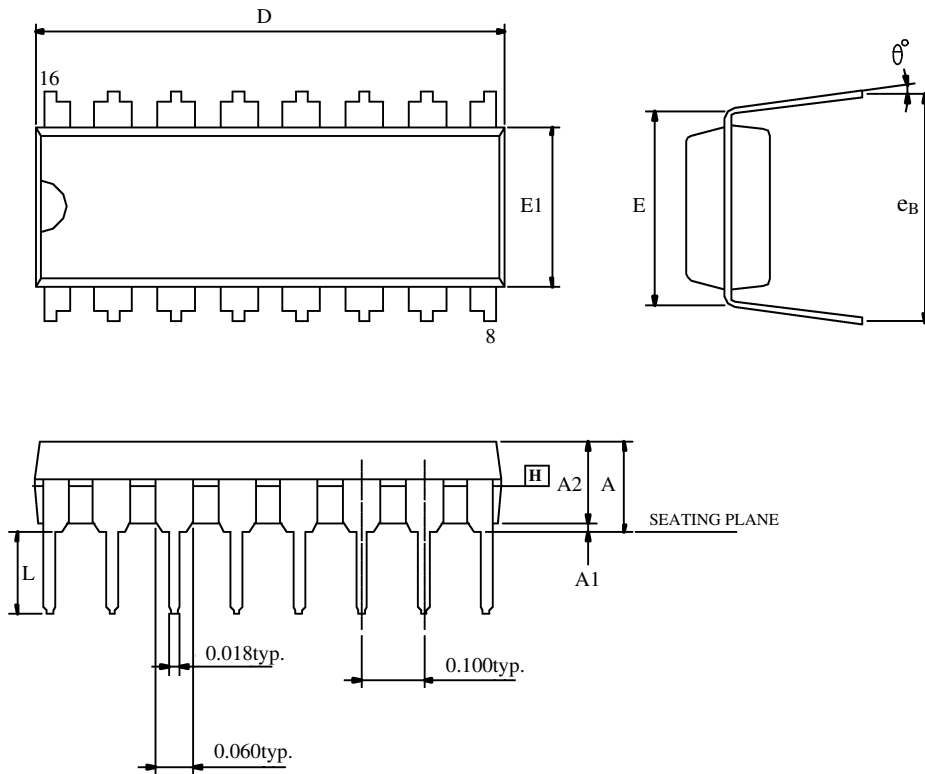

Symbols	MIN.	NOR.	MAX.
A	—	—	0.210
A1	0.015	—	—
A2	0.125	0.130	0.135
D	0.735	0.755	0.775
E	0.300 BSC.		
E1	0.245	0.250	0.255
L	0.115	0.130	0.150
$e_B$	0.335	0.355	0.375
$\theta^0$	0	7	15

UNIT: INCH

NOTES.

1. JEDEC OUTLINE : MS-001 BB
2. "D", "E1" DIMENSIONS DO NOT INCLUDE MOLD FLASH OR PROTRUSIONS. MOLD FLASH OR PROTRUSIONS SHALL NOT EXCEED 0.010 INCH.
3.  $e_B$  IS MEASURED AT THE LEAD TIPS WITH THE LEADS UNCONSTRAINED.
4. POINTED OR ROUNDED LEAD TIPS ARE PREFERRED TO EASE INSERTION.
5. DISTANCE BETWEEN LEADS INCLUDING DAM BAR PROTRUSIONS TO BE 0.005 INCH MINIMUM.
6. DATUM PLANE  $H$  COINCIDENT WITH THE BOTTOM OF LEAD, WHERE LEAD EXIT BODY.

\* CDT assumes no responsibility for the use of the specification described. CDT reserves the right to modify the product specification without notice.  
 ( 以上規格僅供參考，本公司得逕行修正，不另通知 )